

Grid Monitoring Relay User Manual

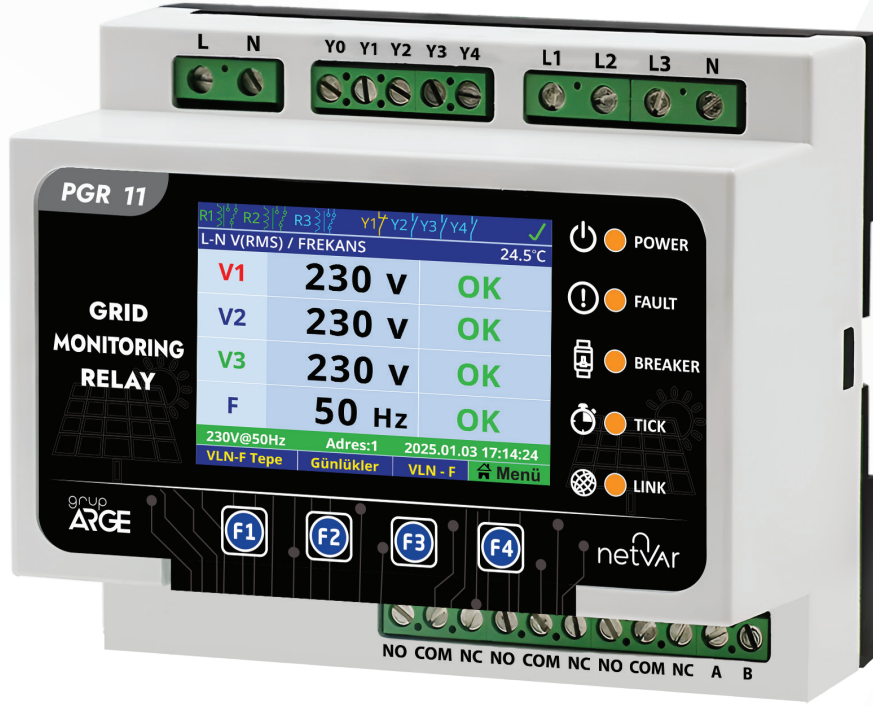

**ADDRESS: Ikitelli OSB Mah. Cevre 14.
Blok Sok. Telas Blok Dış Kapı No: 1
Kat: 1-2 Basaksehir/Istanbul**

**Phone: +90 212 438 80 24
Fax: +90 212 438 80 25**

info@gruparge.com

CONTENTS

PROPER USE and SAFETY REQUIREMENTS	3
1. INTRODUCTION	4
1.1. General Features	4
1.2. Key Features	4
1.3. Inputs and Outputs	4
1.4. Display and Buttons	5
1.5. LEDs	5
2. FUNCTIONS	6
3. COMPATIBILITY	6
4. INPUTS-OUTPUTS	6
4.1. Device Feed Input and Operating Features	6
4.2. Voltage and Frequency Input	6
4.3. Digital Input Features	7
4.4. Relay Outputs	7
5. GRID MONITORING RELAY ERROR CONDITIONS	8
6. CONFIGURATION PARAMETERS	13
7. CIRCUIT BREAKING CONDITIONS	15
8. TECHNICAL DRAWING	15
9. CONNECTION DIAGRAM.....	16
10. MODBUS MAP	17

PROPER USE and SAFETY REQUIREMENTS



Cut all the power when connecting and disconnecting the device to a panel.



Do not clean the device with a solvent or similar material. Only use a dry cloth.



Please do not intervene to the device when a technical problem is encountered and get in contact with a technical service within the shortest time.



If the warnings are not taken into account, our company or the authorized dealer shall not be held responsible for the negative consequences.



Do not dispose in the trash, the device must be delivered to the collection centers (electronic device recycling centers). It should be recycled or disposed of without harming human health and environment.



The installation, assembly, activation and operation of the device should be done and used by only expert professionals and in accordance with safety regulations and instructions.

1. INTRODUCTION

1.1. General Features

This product of the Grup ARGE brand is a multifunctional (Loss of Mains) grid monitoring relay positioned between the main power grid and the renewable energy generation power plant. By continuously monitoring various parameters of the city network, it separates the power plant and the main electricity network within the time specified by the user or specifications in case of any voltage or frequency disturbance that may occur, and ensures that the renewable generation plant is reactivated when the system reaches its nominal value. The device can be explained under the following headings.

Grid monitoring relay: 3 phase-neutral voltages, phase-neutral and phase-phase voltages, frequency, voltage and frequency drift can be measured and displayed on the screen. In addition, it saves the error conditions determined in the device in its memory. Many necessary adjustments related to the device (V_{min} , V_{max} , F_{min} , F_{max}) can be made through the menu. Thanks to the communication system, all read parameters can be monitored remotely via standard MODBUS protocol and various adjustments can be made.

1.2. Key Features

- Microprocessor Based Monitoring and Control
- **Wide Range Supply:** 85-265 V AC / 24-265 V DC
- **Maximum Measurement Voltage:** 500 V AC RMS (500Vp) (Phase - Phase: 800 V)
- Neutral Interruption Detection
- **Frequency Measurement Range:** 40-70 Hz
- Ease of Communication with RS-485 Modbus RTU Protocol and 247 Different Modbus Address

1.3. Inputs and Outputs

- 24-265 V AC-DC Supply Input
- 1 24 V DC Output
- 1 MODBUS RS485 Port
- 4 Digital Inputs
- 3 Relay Outputs 230 V AC / 32 V DC 10A
- 3 Phase - Neutral Analog Voltage Measurement Input

1.4. Display and Buttons

- 2.4" TFT-LCD Panel
- Instant Voltage and Frequency Monitoring
- Setting Protection and Communication Data with the Buttons Located Below the Screen
- Real-Time Recording and Monitoring of Alarm Conditions

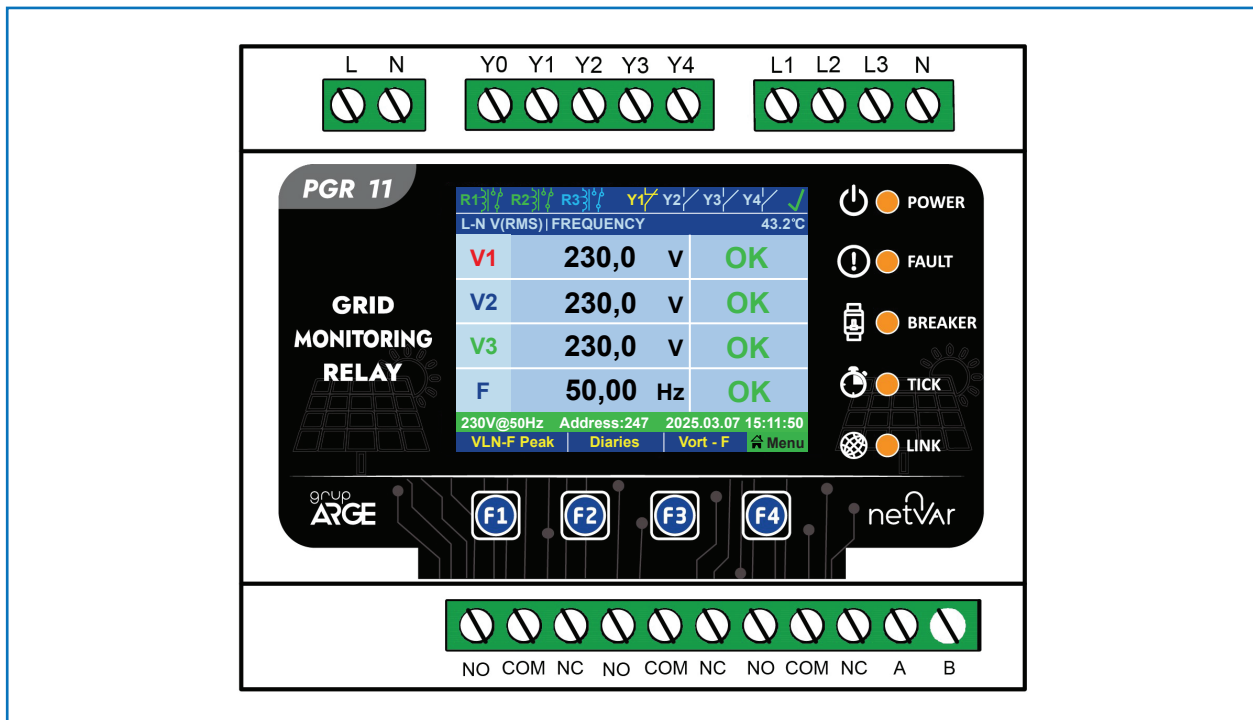

Power, communication, fault and breaker position led indicators (LED indicators are directly related to the control system apart from the TFT panel. In case of failure of the screen, the status can be monitored from the led indicators).

1.5. LEDs

Power: Indicates whether the device is energized or not.

Fault: This LED flashes when the device goes out of the specified voltage and frequency values.

Breaker: Indicates whether the breaker is opened or not.

Tick: The breaker closure countdown LED lights up when it enters the specified voltage and frequency values.

Link: LED flashes when communication is taking place.

2. FUNCTIONS

- Low and High Voltage 1st Step Trip / Protection
- Low and High Voltage 2nd Step Trip / Protection
- Low and High Frequency 1st Step Trip / Protection
- Low and High Frequency 2nd Step Trip / Protection
- Trip / Protection Against Incremental Frequency Change Per Second (ROCOF)
- Trip / Protection Against Voltage Angle Shift (Vector Shift)

3. COMPATIBILITY

- EMC - Immunity EN 61000-6-2
- EMC - Emission EN 61000-6-3

4. INPUTS – OUTPUTS

4.1. Device Feed Input and Operating Features

- **AC:** 24-265 V (45-65 Hz), < 6VA,
- **DC:** 24-265 V < 6W
- **Surge Resistance:** 5000 V
- **Operating Temperature:** -20 °C / +55 °C

4.2. Voltage and Frequency Input

Voltage

- **Measurement Phase-Phase:** AC 0-865 V (Resolution: 0.1 V)
- **Measurement Phase-Neutral:** AC 0-500 V (Resolution: 0.1 V)
- **Phase-Neutral Adjustment Range:** AC 15-299 V (Resolution: 0.1 V)
- **Measurement Method:** True RMS
- **Measurement Functions:** Measurement with / without Neutral

Frequency

- **Measurement Range:** 40-70 Hz
- **Adjustment Range:** 40-65 Hz
- **Measurement Accuracy:** $\pm 0,01 \text{ Hz} \pm 1 \text{ Digit}$

4.3. Digital Input Features

There are 4 digital inputs.

The +24V coming from Y0 can be connected to Y1/Y2/Y3/Y4 terminals by returning from the auxiliary contacts of the contactors.

- Breaker Relay (Y1)
- Emergency Button (Adjustable) (Y2, Y3, Y4)
- Remote On/Off (Adjustable) (Y2, Y3, Y4)
- Leakage Current Relay Detection (Adjustable) (Y2, Y3, Y4)

4.4. Relay Outputs

The device has 3 relay outputs. The 1st and 2nd relay can be configured according to the function of the breaker. How the 3rd relay should work together with the first two relays can be set in various ways.

5. NETWORK MONITORING RELAY ERROR CONDITIONS

Under Voltage Stage 1

This fault occurs when the “Under Voltage Stage 1” protection function is triggered for the relevant phase (trip threshold and delay time).

R1	R2	R3	Y1	Y2	Y3	Y4	X
L-N V(RMS) FREQUENCY							25.7°C
V1	230,0	V	OK				
V2	161,0	V	U<<				
V3	230,0	V	OK				
F	50,00	Hz	OK				
230V@50Hz Address:247 2025.03.07 14:41:45							
VLN-F Top		Diaries		Vort - F		Menu	

U<<

Over Voltage Stage 1

This fault occurs when the “Over Voltage Stage 1” protection function is triggered for the relevant phase (trip threshold and delay time).

R1	R2	R3	Y1	Y2	Y3	Y4	X
L-N V(RMS) FREQUENCY							25.7°C
V1	230,0	V	OK				
V2	299,0	V	U>>				
V3	230,0	V	OK				
F	50,00	Hz	OK				
230V@50Hz Address:247 2025.03.07 14:48:22							
VLN-F Top		Diaries		Vort - F		Menu	

U>>

R1	R2	R3	Y1	Y2	Y3	Y4	X
L-N V(RMS) FREQUENCY							25.7°C
V1	230,0	V	OK				
V2	184,0	V	U<				
V3	230,0	V	OK				
F	50,00	Hz	OK				
230V@50Hz Address:247 2025.03.07 14:23:16							
VLN-F Top		Diaries		Vort - F		Menu	

U<

Under Voltage Stage 2

This fault occurs when the “Under Voltage Stage 2” protection function is triggered for the relevant phase (trip threshold and delay time).

R1	R2	R3	Y1	Y2	Y3	Y4	X
L-N V(RMS) FREQUENCY							25.7°C
V1	230,0	V	OK				
V2	276,0	V	U>				
V3	230,0	V	OK				
F	50,00	Hz	OK				
230V@50Hz Address:247 2025.03.07 14:45:02							
VLN-F Top		Diaries		Vort - F		Menu	

U>

Over Voltage Stage 2

This fault occurs when the “Over Voltage Stage 2” protection function is triggered for the relevant phase (trip threshold and delay time).

Average Over Voltage

This fault occurs when the “Average Over Voltage” protection function is triggered for the relevant phase (trip threshold and delay time).

R1	R2	R3	Y1	Y2	Y3	Y4	X
L-N Vort(RMS) FREQUENCY							25.7°C
V1Av	230,0	V	OK				
V2Av	253,0	V	UM>				
V3Av	230,0	V	OK				
F	50,00	Hz	OK				
SN:00000008 Address:247 2025.03.07 15:50:53							
VLN-F		VShft -F		Menu			

UM>

R1	R2	R3	Y1	Y2	Y3	Y4	X
L-N V(RMS) FREQUENCY							25.7°C
V1	230,0	V	OK				
V2	230,0	V	OK				
V3	230,0	V	OK				
F	50,00	Hz	ROCOF				
230V@50Hz Address:247 2025.03.07 15:11:50							
VLN-F Top		Diaries		Vort - F		Menu	

ROCOF

ROCOF Protection

This fault occurs when the “ROCOF” (Rate of Change of Frequency) protection function is triggered (trip threshold, number of cycles measured, and delay time).

Vector Shift

This fault occurs when the “Vector Shift” protection function is triggered (trip threshold and fault duration).

R1	R2	R3	Y1	Y2	Y3	Y4	X
L-N V(RMS) FREQUENCY							25.7°C
V1	230,0	V	OK				
V2	230,0	V	VS				
V3	230,0	V	OK				
F	50,00	Hz	OK				
Network Disconnection: 4 sec.							
VLN-F Top		Diaries		Vort - F		Menu	

VS

Under Frequency Stage 1

This fault occurs when the “Under Frequency Stage 1” protection function is triggered for the relevant phase (trip threshold and delay time).

R1	R2	R3	Y1	Y2	Y3	Y4	X
L-N V(RMS) FREQUENCY							25.7°C
V1	230,0	v	OK				
V2	230,0	v	OK				
V3	230,0	v	OK				
F	47,00	Hz	F<				
230V@50Hz Address:247 2025.03.07 15:08:50							
VLN-F Top		Diaries		Vort - F		Menu	

F<

Under Frequency Stage 2

This fault occurs when the “Under Frequency Stage 2” protection function is triggered for the relevant phase (trip threshold and delay time).

R1	R2	R3	Y1	Y2	Y3	Y4	X
L-N V(RMS) FREQUENCY							25.7°C
V1	230,0	v	OK				
V2	230,0	v	OK				
V3	230,0	v	OK				
F	45,00	Hz	F<<				
Network Interrupted: Low Frequency (F<)							
VLN-F Top		Diaries		Vort - F		Menu	

F<<

Over Frequency Stage 1

This fault occurs when the “Over Frequency Stage 1” protection function is triggered for the relevant phase (trip threshold and delay time).

R1	R2	R3	Y1	Y2	Y3	Y4	X
L-N V(RMS) FREQUENCY							25.7°C
V1	230,0	v	OK				
V2	230,0	v	OK				
V3	230,0	v	OK				
F	51,00	Hz	F>				
230V@50Hz Address:247 2025.03.07 15:11:50							
VLN-F Top		Diaries		Vort - F		Menu	

F>

Over Frequency Stage 2

This fault occurs when the “Over Frequency Stage 2” protection function is triggered for the relevant phase (trip threshold and delay time).

R1	R2	R3	Y1	Y2	Y3	Y4	X
L-N V(RMS) FREQUENCY							25.7°C
V1	230,0	v	OK				
V2	230,0	v	OK				
V3	230,0	v	OK				
F	52,00	Hz	F>>				
SN:00000008 Address:247 2025.03.07 15:12:53							
VLN-F Top		Diaries		Vort - F		Menu	

F>>

Feedback Error

This fault occurs due to a “**Feedback Error**” on the Y1 input. After the issue is resolved, the connection can be restored by pressing and holding the menu button for 3 seconds.

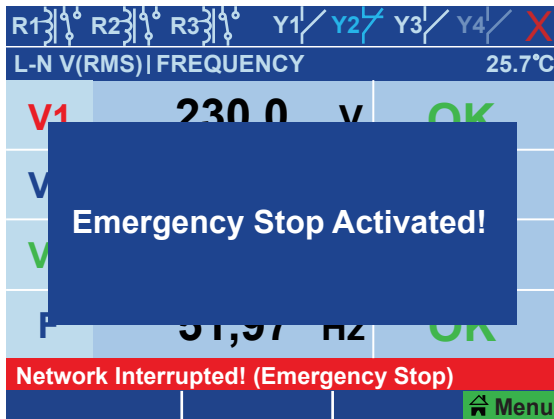
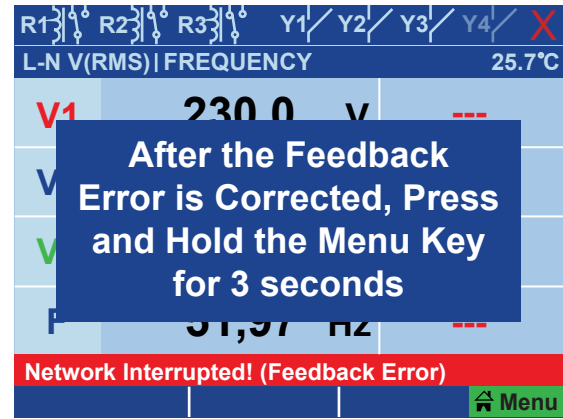

Emergency Stop

This screen appears when the input programmed as “**Emergency Stop**” is activated. After the input is deactivated and connection conditions are met, the grid reconnects automatically following the delay time.

Grid Disconnection via Menu Button

The grid connection can be interrupted by holding the “**Menu Button (F4)**” for 5 seconds. A countdown is displayed at the bottom of the screen during the hold.

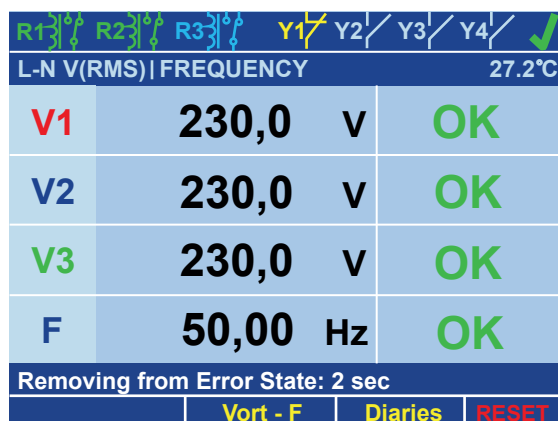
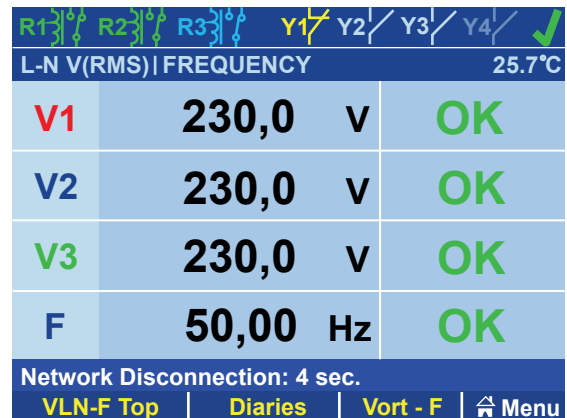

Grid Connection via Menu Button

This status screen can be used to reactivate the system when the system is disabled in any case or when the system is intervened by the user. When the “**Menu Button (F4)**” is pressed for 5 seconds, the RESET icon appears and if the connection conditions are met, the connection is established.

Remote or Manual Shutdown

This screen appears when the “**Remote Shutdown**” function is used or the menu button(F4) is held for 5 seconds. To reconnect, hold the menu button for 3 seconds or activate the remote start input.

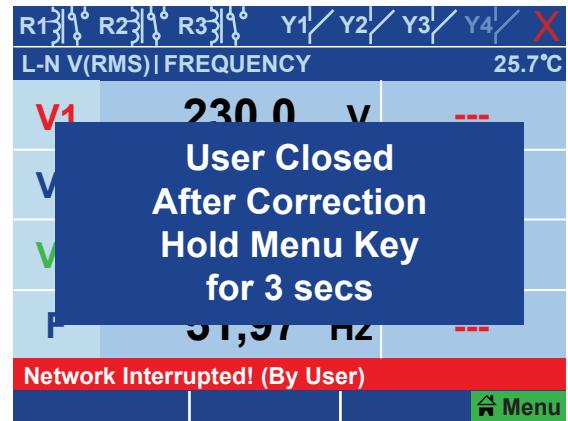

R1	R2	R3	Y1	Y2	Y3	Y4	X
L-N	V(RMS)	FREQUENCY	25.7°C				
V1	230,0	v	OK				
V2	230,0	v	OK				
V3	230,0	v	OK				
F	50,00	Hz	OK				
Remaining Time for Network Connection: 5 sec.							
VLN-F Top		Diaries		Vort - F		Menu	

Remote Start

This screen appears when the input programmed as “**Remote Start**” is triggered. If connection conditions are met, the grid connection is re-established.

Leakage Current Detection

This screen appears when the input programmed as “**Leakage Current Detection**” is triggered. The grid disconnects when the leakage relay is activated, and reconnects automatically after deactivation and a delay period.

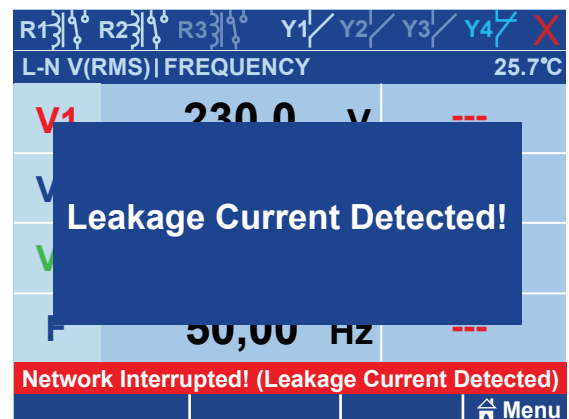

6. CONFIGURATION PARAMETERS

Menu		Configuration Options	Setting Range		
Grid Connection	Nominal Voltage		50-300 V		
	Connection Control	Measurement Break Detection	-		
		Neutral Break Detection	-		
Grid Monitoring	Voltage	Over Voltage U> (59>S2)	Cut-off Threshold Value	69-345 V	x0.005
			Binding Threshold Value	57,5-333,5 V	x0.005
			Cutting Delay Time	0-600 s	10 ms
			Binding Delay Time	0.05-600 s	10 ms
		Over Voltage U>> (59>S2)	Cut-off Threshold Value	69-345 V	x0.005
			Binding Threshold Value	57,5-333,5 V	x0.005
			Cutting Delay Time	0-600 s	10 ms
			Binding Delay Time	0.05-600 s	10 ms
		Under Voltage U< (27<S1)	Cut-off Threshold Value	57,5-333,5 V	x0.005
			Binding Threshold Value	69-345 V	x0.005
			Cutting Delay Time	0-600 s	10 ms
			Binding Delay Time	0.05-600 s	10 ms
		Under Voltage U<< (27<S2)	Cut-off Threshold Value	57,5-333,5 V	x0.005
			Binding Threshold Value	69-345 V	x0.005
			Cutting Delay Time	0-600 s	10 ms
			Binding Delay Time	0.05-600 s	10 ms
		Average Over Voltage UM	Cut-off Threshold Value	6,9-333,5 V	x0.005
			Binding Threshold Value	5,7-345 V	x0.005
			Cutting Delay Time	0-600 s	10 ms
			Binding Delay Time	0.05-600 s	10 ms
	Frequency	Over Frequency F> (81<S2)	Cut-off Threshold Value	40-62 Hz	0.01 Hz
			Binding Threshold Value	42-65 Hz	0.01 Hz
			Cutting Delay Time	0-600 s	10 ms
			Binding Delay Time	0.05-600 s	10 ms
		Over Frequency F>> (81>S2)	Cut-off Threshold Value	40-62 Hz	0.01 Hz
			Binding Threshold Value	42-65 Hz	0.01 Hz
			Cutting Delay Time	0-600 s	10 ms
			Binding Delay Time	0.05-600 s	10 ms
		Under Frequency F< (81<S1)	Cut-off Threshold Value	42-65 Hz	0.01 Hz
			Binding Threshold Value	40-62 Hz	0.01 Hz
			Cutting Delay Time	0-600	10 ms
			Binding Delay Time	0.05-600 s	10 ms
		Under Frequency F<< (81<S2)	Cut-off Threshold Value	42-65 Hz	0.01 Hz
			Binding Threshold Value	40-62 Hz	0.01 Hz
			Cutting Delay Time	0-600	10 ms
			Binding Delay Time	0.05-600 s	10 ms
	ROCOF	Threshold Value		0.1-5 Hz	0.005 Hz
		Number of Periods		4-50	1
		Cutting Delay Time		0-600 s	10 ms
		Binding Delay Time		0.05-600 s	10 ms
Vector Shifting	Threshold Value		2-60°	0.1°	
	Error Duration		3-600 s	1 s	
Switch-on Condition	Voltage Range		57.5-333.5 V(x0.250-x1450)	x0.005	
	Frequency Range		1-65 Hz	0.01 Hz	
	Delay Time		100 min	1 s	

Input / Output Setting	Feedback (Y1)	Connection Type		Normally Open (NO), Normally Close (NC)	-	
		Function		Y1, Devre Dışı	-	
		Cutting Delay Time		1-600 s	1 s	
		Binding Delay Time		1-999 s	1 s	
		Automatic Binding		0-255	1	
	Digital Input (Y2-Y3-Y4)	Input-Y2	Connection Type		Normally Open (NO), Normally Close (NC)	-
			Function		Emergency Stop, Leakage Current Relay Detection, Remote On, Remote Off, Y1 Disable, Deactivate	-
		Input-Y3	Connection Type		Normally Open (NO), Normally Close (NC)	-
			Function		Emergency Stop, Leakage Current Relay Detection, Remote On, Remote Off, Y1 Disable, Deactivate	-
		Input-Y4	Connection Type		Normally Open (NO), Normally Close (NC)	-
			Function		Emergency Stop, Leakage Current Relay Detection, Remote On, Remote Off, Y1 Disable, Deactivate	-
		Digital Output	Output - K1	Function	Switch-on Trigger	100ms - 30s
					Switch-off Trigger	100ms - 30s
					Continuous	-
					Deactivated	-
			Output - K2	Function	Switch-on Trigger	100ms - 30s
					Switch-off Trigger	100ms - 30s
	Continuous				-	
	Deactivated				-	
	Output - K3 (User)		Function	Synchronous - K1	-	
				Asynchronous - K1 (0-30s Delay)	0sn - 10s	
				Synchronous - K2	-	
				Asynchronous - K2 (0-30s Delay)	0sn - 10s	
			Continuously Activated	-		
			Timed Activated	0sn - 10s		
	Breaker Meter Information	Number of Breaker Openings			-	
		Number of Breaker Closures			-	
Delete / Reset			-			
Warning and Event Logging	List Screen Settings	List Selection		Warnings, Events & Warnings, Events	-	
		Alarm Selection		5-250	1	
		Filter Duration		0-255	1 s	
		Delete List			-	
	Error Logging			Deactivated - Activated	-	
	Device Settings	Date and Time			YY/MM/DD hh/mm/ss	
Modbus Configuration		Modbus Address		1-247	1	
		Modbus Speed		4800, 9600, 19200, 38400, 57600, 115200, 256000	-	
		Data, Stop Bits and Parity	Number of Data Bits		-	
			Parity Setting	Single, Double, Empty	-	
			Number of Stop Bits	1, 2	-	
		Silent Interval		4-128	1	
		Mode		ASCII, RTU	-	
		Modbus Protection	Reading Protection		-	
			Writing Protection		-	
			Reading Password		-	
Writing Password			-			
Delete Peak Values			-			
Display settings		Average	Number of Samples	1-16	1	
			Refresh Period	0.1-1s	100 ms	
			Control Percentage	5 % - 50 %	1%	
		Password Protection			-	
		Access Level			-	
		Display Protector			-	
		Display Timeout		2-240 min	1 min	
Brightness Level		5 % - 100 %	1%			
Time Zone (GMT)		-12 - 12	1			
Expert Settings		Default Settings			-	
		Device Reset			-	
		Make Quality Control			-	

7. CIRCUIT BREAKING CONDITIONS

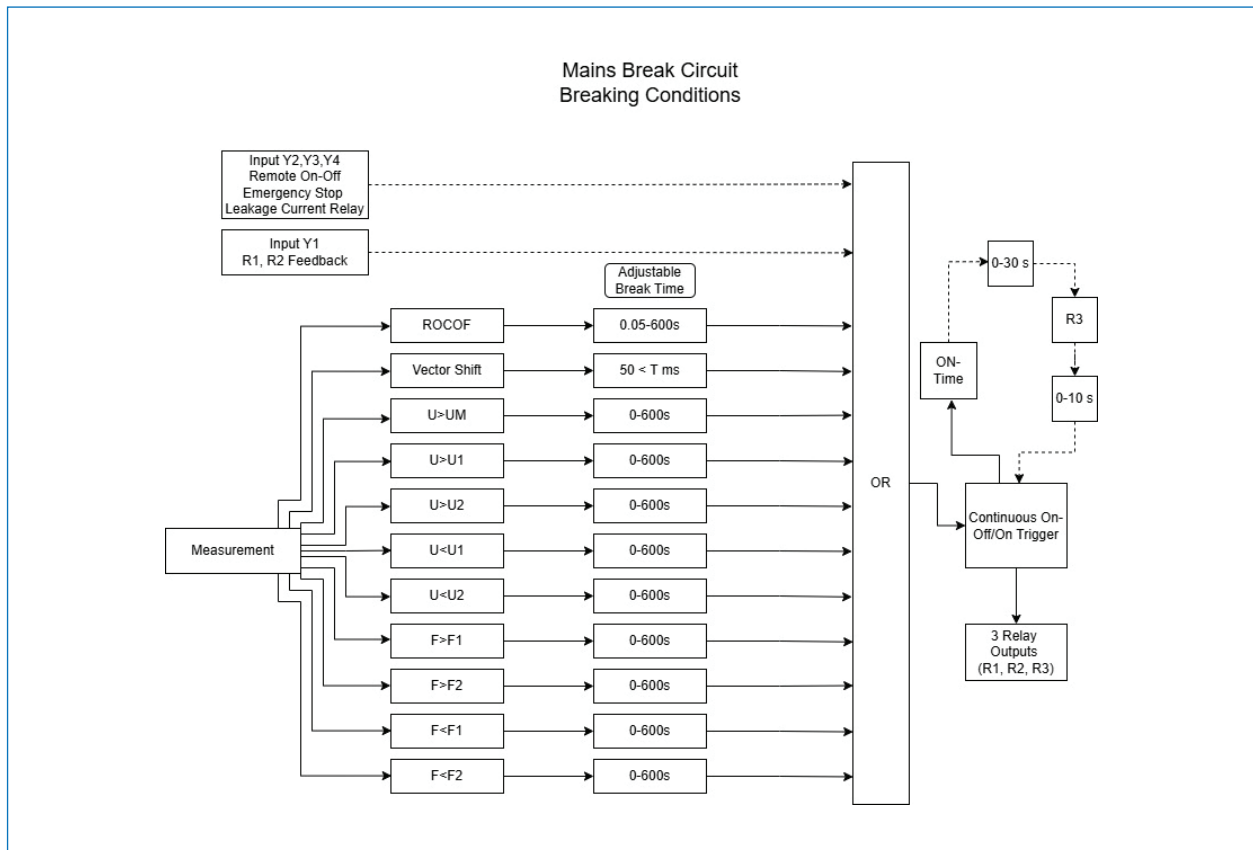

8. TECHNICAL DRAWING

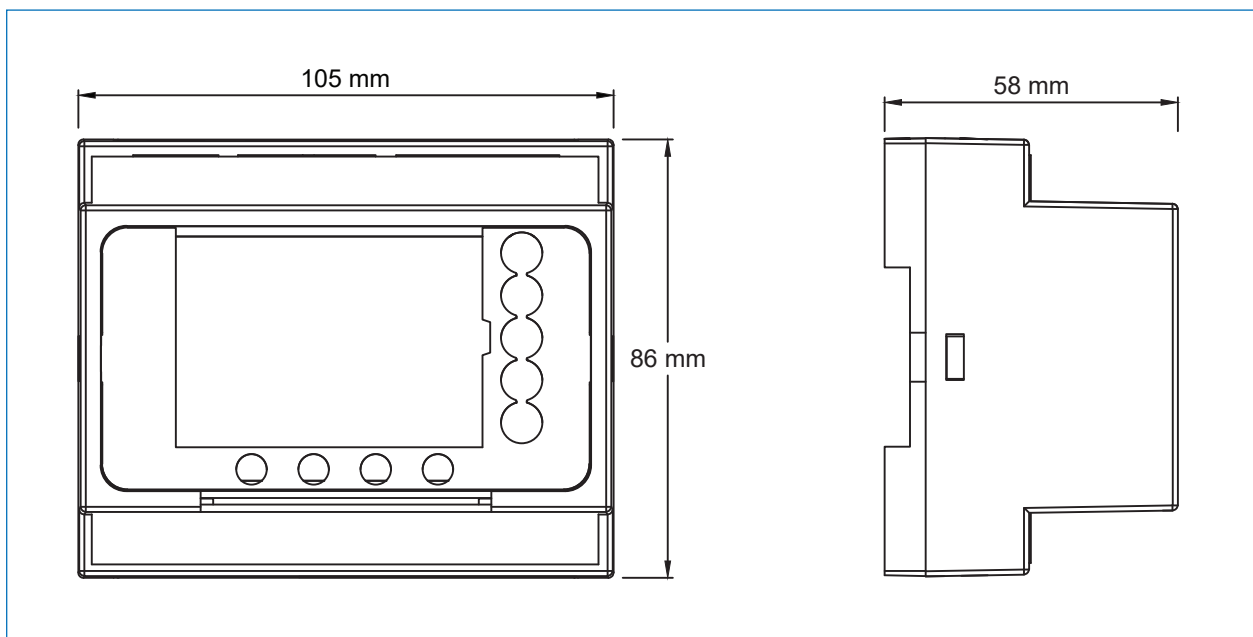

9. CONNECTION DIAGRAM

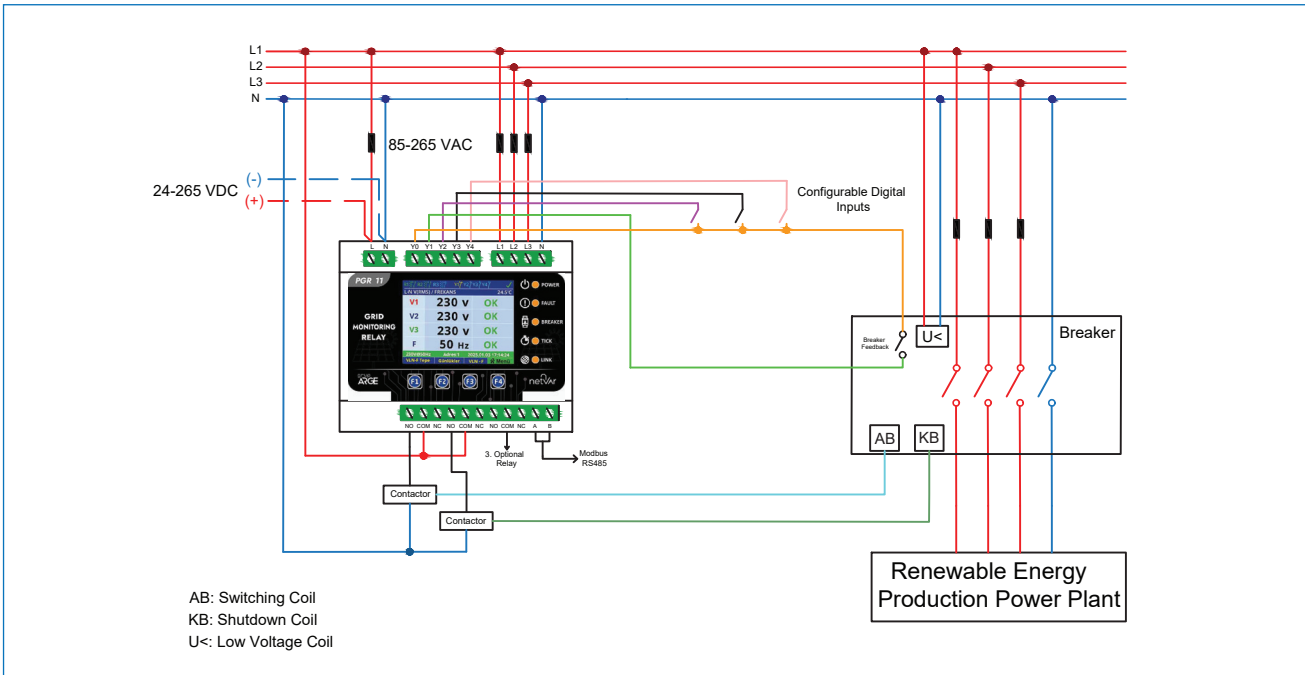

Pulse Mode (Discrete Mode): To operate in this mode;
 INPUT / OUTPUT SETTINGS -> Relay Output -> Output-K1 -> Mode -> Open Trigger
 INPUT / OUTPUT SETTINGS -> Relay Output -> Output-K2 -> Mode -> Close Trigger.

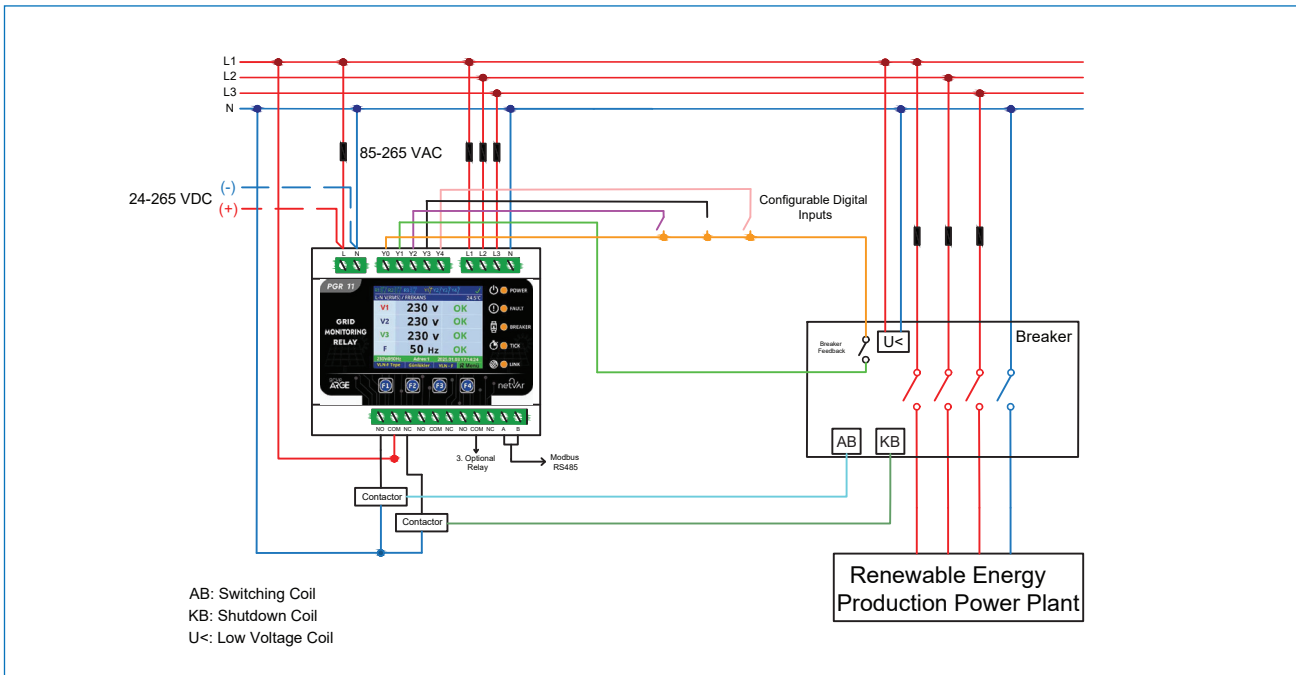

Continuous Mode (Continuous Operation): To operate in this mode;
 INPUT / OUTPUT SETTINGS -> Relay Output -> Output-K1 -> Mode -> Continuous
 INPUT / OUTPUT SETTINGS -> Relay Output -> Output-K2 -> Mode -> Continuous.

NOTE: In systems that do not have a low voltage coil in the switch and operate only with an on-off coil, it is recommended to use a UPS (Uninterruptible Power Supply) to ensure control integrity against power outages.

In order to monitor contact status and provide remote control functions reliably, it is recommended that the control circuit and device be supplied via a 24V DC output rectifier.

10. MODBUS MAP

Parameter	Address	Type	Unit	W/R	Min	Max	Default	Step
Modbus Address	206	Uint_16	-	W/R	1	247	1	1
Modbus Speed (Table-2)*	210	Uint_16	bps	W/R	0	5	1	1
Time Zone (GMT)	249	int_16	-	W/R	-12	12	3	1
Date Time Timestamp (High)	250	Uint_16	-	W/R	0	65535	0	1
Date Time Timestamp (Low)	251	Uint_16	-	W/R	0	65535	0	1
Screen Sample Count	252	Uint_16	-	W/R	1	16	8	1
Screen Percentage Difference	253	Uint_16	%	W/R	1	60	30	1
Screen Refresh Interval	254	Uint_16	ms	W/R	300	10000	300	100
Screen Saver Activation	256	Uint_16	-	W/R	0	1	1	-
Screen Saver Standby Time	257	Uint_16	dk	W/R	3	240	60	1
Screen Brightness Level	258	Uint_16	%	W/R	5	100	90	1
Language	260	Uint_16	-	W/R	0	1	0	-
Access Level (Table-7)	261	Uint_16	-	W/R	0	2	0	-
Access Control Activation	262	Uint_16	-	W/R	0	1	0	-
Nominal Voltage	265	Uint_16	-	W/R	50	300	230	1
Measurement Disconnection Detection	268	Uint_16	table	W/R	0	1	0	-
Neutral Disconnection Detection	269	Uint_16	table	W/R	0	1	1	-
Overvoltage (U<) Activation (Table-1)	270	Uint_16	-	W/R	0	1	1	-
Overvoltage (U<) Cut Threshold Value	271	Uint_16	-	W/R	100	1300	1250	5
Overvoltage (U<) Connecting Threshold Value	272	Uint_16	-	W/R	100	1300	1125	5
Overvoltage (U<) Cut Delay Time	274	Uint_32	ms(x10)	W/R	0	60000	20	1
Overvoltage (U<) Connecting Delay Time	276	Uint_32	ms(x10)	W/R	0	60000	200	1
Overvoltage (U>>) Activation (Table-1)	280	Uint_16	table	W/R	0	1	0	-
Overvoltage (U>>) Cut Threshold Value	281	Uint_16	-	W/R	100	1300	1150	5
Overvoltage (U>>) Connecting Threshold	282	Uint_16	-	W/R	100	1300	1050	5
Overvoltage (U>>) Cut Delay Time	284	Uint_32	ms(x10)	W/R	0	60000	20	1
Overvoltage (U>>) Connecting Delay Time	286	Uint_32	ms(x10)	W/R	0	60000	200	1
Low Voltage (U<) Activation (Table-1)	290	Uint_16	-	W/R	0	1	1	-
Low Voltage (U<) Cut Threshold Value	291	Uint_16	-	W/R	100	1300	800	5
Low Voltage (U<) Connecting Threshold Value	292	Uint_16	-	W/R	100	1300	725	5
Low Voltage (U<) Cut Delay Time	294	Uint_32	ms(x10)	W/R	0	60000	20	1
Low Voltage (U<) Connecting Delay Time	296	Uint_32	ms(x10)	W/R	0	60000	200	1
Low Voltage (U<<) Activation (Table-1)	300	Uint_16	table	W/R	0	1	1	-
Low Voltage (U<<) Cut Threshold Value	301	Uint_16	-	W/R	100	1300	450	5
Low Voltage (U<<) Cut Threshold Value	302	Uint_16	-	W/R	100	1300	400	5
Low Voltage (U<<) Cut Delay Time	304	Uint_32	ms(x10)	W/R	0	60000	20	1
Low Voltage (U<<) Connecting Delay Time	306	Uint_32	ms(x10)	W/R	0	60000	200	1
Over Voltage (UM>) Activation (Table-1)	310	Uint_16	table	W/R	0	1	0	-
Over Voltage (UM>) Cut Threshold Value	311	Uint_16	-	W/R	100	1300	1100	5
Over Voltage (UM>) Connecting Threshold Value	312	Uint_16	-	W/R	100	1300	1000	5
Over Voltage (UM>) Cut Delay Time	314	Uint_32	sec	W/R	0	60000	20	-
Over Voltage (UM>) Connecting Delay Time	316	Uint_32	sec	W/R	0	60000	200	-
Over Frequency (F>) Activation (Table-1)	320	Uint_16	-	W/R	0	1	1	-
Over Frequency (F>) Cut Threshold Value	321	Uint_16	hz(x0.01)	W/R	4000	6500	5150	1
Over Frequency (F>) Connecting Threshold Value	322	Uint_16	hz(x0.01)	W/R	4000	6500	5050	1
Over Frequency (F>) Cut Delay Time	324	Uint_32	ms(x10)	W/R	0	60000	50	1
Over Frequency (F>) Connecting Delay Time	326	Uint_32	ms(x10)	W/R	0	60000	200	1
Over Frequency (F>>) Activation (Table-1)	330	Uint_16	table	W/R	0	1	0	-
Over Frequency (F>>) Cut Threshold Value	331	Uint_16	hz(x0.01)	W/R	4000	6500	5150	1
Over Frequency (F>>) Connecting Threshold Value	332	Uint_16	hz(x0.01)	W/R	4000	6500	5050	1
Over Frequency (F>>) Cut Threshold Value	334	Uint_32	ms(x10)	W/R	0	60000	50	1
Over Frequency (F>>) Connecting Delay Time	336	Uint_32	ms(x10)	W/R	0	60000	200	1
Low Frequency (F<) Activation (Table-1)	340	Uint_16	table	W/R	0	1	1	-
Low Frequency (F<) Cut Threshold Value	341	Uint_16	hz(x0.01)	W/R	4000	6500	4750	1
Low Frequency (F<) Connecting Threshold Value	342	Uint_16	hz(x0.01)	W/R	4000	6500	4850	1
Low Frequency (F<) Cut Delay Time	344	Uint_32	ms(x10)	W/R	0	60000	50	1
Low Frequency (F<) Connecting Delay Time	346	Uint_32	ms(x10)	W/R	0	60000	200	1
Low Frequency (F<<) Activation (Table-1)	350	Uint_16	table	W/R	0	1	0	-
Low Frequency (F<<) Cut Threshold Value	351	Uint_16	hz(x0.01)	W/R	4000	6500	4750	1
Low Frequency (F<<) Connecting Threshold Value	352	Uint_16	hz(x0.01)	W/R	4000	6500	4850	1
Low Frequency (F<<) Cut Delay Time	354	Uint_32	ms(x10)	W/R	0	60000	50	1
Low Frequency (F<<) Connecting Delay Time	356	Uint_32	ms(x10)	W/R	0	60000	200	1

Table-1	
Index	Status
0	Disabled
1	Activated

Table-2	
Index	Modbus Speed
0	4800 bps
1	9600 bps
2	19200 bps
3	38400 bps
4	57600 bps
5	115200 bps

Table-3	
Index	User Output(K3) Mode
0	Disabled
1	Synchronous(R1 and R2)
2	Asynchronous(R1 and R2)
3	Permanently Activated
4	Timed Activated

Table-4	
Index	Connection Type
0	Normally Open
1	Normally Closed

Table-5	
Index	Input Function
0	Disabled
1	Emergency Stop
2	Generator Detection
3	Remote Switch-on
4	Remote Switch Off
5	Y1 Disable

Table-6	
Index	Feedback Function
0	Y1
1	Disabled

Table-7	
Index	Access Level
1	Operator
2	Expert

Table-8	
Index	Alarm List Type

Table-9	
Index	Output Mode
0	Disabled
1	Switch-On Trigger
2	Switch Off Trigger
3	Permanent

Rocof Activation (Table-1)	360	Uint_16	table	W/R	0	1	0	-
Rocof Threshold Value	361	Uint_16	hz(x0.001)	W/R	100	5000	1000	5
Rocof Period Number	362	Uint_16	-	W/R	4	50	8	1
Rocof Connecting Delay Time	364	Uint_32	ms(x10)	W/R	0	60000	50	1
Rocof Period Number	366	Uint_32	ms(x10)	W/R	0	60000	200	1
Vector Shift Activation (Table-1)	370	Uint_16	table	W/R	0	1	0	-
Vector Shift Threshold Value	371	Uint_16	-	W/R	-	-	-	-
Vector Shift Error Time	372	Uint_16	sec	W/R	3	600	30	
Voltage Range Activation (Table-1)	375	Uint_16	table	W/R	0	1	1	-
Voltage Range Maximum	376	Uint_16	-	W/R	1000	1300	1100	5
Voltage Range Minimum	377	Uint_16	-	W/R	100	1000	850	5
Frequency Range Activation (Table-1)	380	Uint_16	table	W/R	0	1	1	-
Frequency Range Maximum	381	Uint_16	hz(x0.01)	W/R	4500	6000	5050	1
Frequency Range Minimum	382	Uint_16	hz(x0.01)	W/R	500	6500	4950	1
Activation Delay Time	386	Uint_16	sec	W/R	3	6000	10	-
User Output (K3) Mode (Table-3)	390	Uint_16	table	W/R	0	4	0	1
User Logout (K3) Delay Time	392	Uint_16	ms	W/R	0	30000	1000	100
User Output (K3) Open Time	393	Uint_16	ms	W/R	0	10000	1000	100
Input (Y2) Connection Type (Table-4)	396	Uint_16	table	W/R	0	1	0	1
Input (Y2) Function (Table-5)	397	Uint_16	table	W/R	0	5	0	1
Input (Y3) Connection Type (Table-4)	398	Uint_16	table	W/R	0	1	0	1
Input (Y3) Function (Table-5)	399	Uint_16	table	W/R	0	5	0	1
Input (Y4) Connection Type (Table-4)	400	Uint_16	table	W/R	0	1	0	1
Input (Y4) Function (Table-5)	401	Uint_16	table	W/R	0	5	0	1
Feedback (Y1) Connection Type (Table-4)	405	Uint_16	table	W/R	0	1	0	1
Feedback (Y1) Function (Table-6)	406	Uint_16	table	W/R	0	4	0	1
Feedback (Y1) Interrupt Delay Time	407	Uint_16	sec	W/R	1	60	5	1
Feedback (Y1) Connecting Delay Time	408	Uint_16	sec	W/R	1	999	10	1
Automatic Connection	409	Uint_16	-	W/R	0	255	3	1
Output (K1) Mode (Table-9)	412	Uint_16	table	W/R	0	4	0	1
Output (K1) Open Time	413	Uint_16	ms	W/R	0	30000	1000	100
Output (K2) Mode (Table-9)	416	Uint_16	table	W/R	0	4	0	1
Output (K2) Open Time	417	Uint_16	ms	W/R	0	30000	1000	100
Alarm List Type (Table-8)	420	Uint_16	table	W/R	1	60	5	1
Alarm List Number of Elements	421	Uint_16	-	W/R	1	250	25	1
Alarm List Filter Time	422	Uint_16	sec	W/R	0	255	30	1
Company Name_1	440	Uint_16	-	W/R	-	-	-	-
Company Name_2	441	Uint_16	-	W/R	-	-	-	-
Company Name_3	442	Uint_16	-	W/R	-	-	-	-
Company Name_4	443	Uint_16	-	W/R	-	-	-	-
Company Name_5	444	Uint_16	-	W/R	-	-	-	-
Company Name_6	445	Uint_16	-	W/R	-	-	-	-
Company Name_7	446	Uint_16	-	W/R	-	-	-	-
Company Name_8	447	Uint_16	-	W/R	-	-	-	-
Company Name_9	448	Uint_16	-	W/R	-	-	-	-
Company Name_10	449	Uint_16	-	W/R	-	-	-	-
Company Name_11	450	Uint_16	-	W/R	-	-	-	-
Company Name_12	451	Uint_16	-	W/R	-	-	-	-
Company Name_13	452	Uint_16	-	W/R	-	-	-	-
Company Name_14	453	Uint_16	-	W/R	-	-	-	-
Company Name_15	454	Uint_16	-	W/R	-	-	-	-
Company Name_16	455	Uint_16	-	W/R	-	-	-	-
Company Name_17	456	Uint_16	-	W/R	-	-	-	-
Company Name_18	457	Uint_16	-	W/R	-	-	-	-
Company Name_19	458	Uint_16	-	W/R	-	-	-	-
Company Name_20	459	Uint_16	-	W/R	-	-	-	-

Instant Magnitudes	Address	Type	Multiplier	Unit	W/R
Nominal Line Voltage	10030	int 32	1	V	R
Temperature 1	10036	int 32	0.1	Centigrade	R
Date / Time (UTC)	10046	int 32	1	Timestamp	R
Serial Number	10048	int 32	1	-	R
L1 Phase Neutral Voltage	10050	int 32	0.1	Volt	R
L2 Phase Neutral Voltage	10052	int 32	0.1	Volt	R
L3 Phase Neutral Voltage	10054	int 32	0.1	Volt	R
Frequency	10070	int 32	0,01	Hz	R
L1 Vector Shift	10080	int 32	0.1	Degree	R
L2 Vector Shift	10082	int 32	0.1	Degree	R
L3 Vector Shift	10084	int 32	0.1	Degree	R
Breaker Opening Number	10100	int 32	1	-	R
Breaker Closing Number	10102	int 32	1	-	R

LIST NO	WARNINGS AND EVENTS	ADDRESS	DATA TYPE	MULTIPLIER	UNIT	W/R
1	Alarm Number	56000	uint32_t	-	-	R
1	Alarm Type	56002	uint32_t	-	-	R
1	Alarm Time (UTC)	56004	uint32_t	-	-	R
1	Alarm Data	56006	uint32_t	-	-	R
2	Alarm Number	56008	uint32_t	-	-	R
2	Alarm Type	56010	uint32_t	-	-	R
2	Alarm Time (UTC)	56012	uint32_t	-	-	R
2	Alarm Data	56014	uint32_t	-	-	R
3	Alarm Number	56016	uint32_t	-	-	R
3	Alarm Type	56018	uint32_t	-	-	R
3	Alarm Time (UTC)	56020	uint32_t	-	-	R
3	Alarm Data	56022	uint32_t	-	-	R
N	Alarm Number	56000+((N-1)*8)	uint32_t	-	-	R
N	Alarm Type	56002+((N-1)*8)	uint32_t	-	-	R
N	Alarm Time (UTC)	56004+((N-1)*8)	uint32_t	-	-	R
N	Alarm Data	56006+((N-1)*8)	uint32_t	-	-	R

WARNING NO	WARNING NAME
1	Over Voltage (U>) Fault
2	Over Voltage (U>>) Fault
3	Low Voltage (U<) Fault
4	Low Voltage (U<<) Fault
5	Over Voltage (UM>) Fault
6	Over Frequency (F>) Error
7	Over Frequency (F>>) Error
8	Low Frequency (F<) Error
9	Low Frequency (F<<) Error
10	Rocof Error
11	Vector Shift Error
12	Feedback Error
13	Conditional Switch On Error
14	Closed by User
15	Unable to Read Measurement Values
16	Neutral Connection Disconnected
17	System Activated
18	System Disconnected

LIST NO	WARNINGS	ADDRESS	DATA TYPE	MULTIPLIER	UNIT	W/R
1	Alarm Number	57000	uint32_t	-	-	R
1	Alarm Type	57002	uint32_t	-	-	R
1	Alarm Time (UTC)	57004	uint32_t	-	-	R
1	Alarm Data	57006	uint32_t	-	-	R
2	Alarm Number	57008	uint32_t	-	-	R
2	Alarm Type	57010	uint32_t	-	-	R
2	Alarm Time (UTC)	57012	uint32_t	-	-	R
2	Alarm Data	57014	uint32_t	-	-	R
3	Alarm Number	57016	uint32_t	-	-	R
3	Alarm Type	57018	uint32_t	-	-	R
3	Alarm Time (UTC)	57020	uint32_t	-	-	R
3	Alarm Data	57022	uint32_t	-	-	R
N	Alarm Number	57000+((N-1)*8)	uint32_t	-	-	R
N	Alarm Type	57002+((N-1)*8)	uint32_t	-	-	R
N	Alarm Time (UTC)	57004+((N-1)*8)	uint32_t	-	-	R
N	Alarm Data	57006+((N-1)*8)	uint32_t	-	-	R

LIST NO	EVENTS	ADDRESS	DATA TYPE	MULTIPLIER	UNIT	W/R
1	Alarm Number	58000	uint32_t	-	-	R
1	Alarm Type	58002	uint32_t	-	-	R
1	Alarm Time (UTC)	58004	uint32_t	-	-	R
1	Alarm Data	58006	uint32_t	-	-	R
2	Alarm Number	58008	uint32_t	-	-	R
2	Alarm Type	58010	uint32_t	-	-	R
2	Alarm Time (UTC)	58012	uint32_t	-	-	R
2	Alarm Data	58014	uint32_t	-	-	R
3	Alarm Number	58016	uint32_t	-	-	R
3	Alarm Type	58018	uint32_t	-	-	R
3	Alarm Time (UTC)	58020	uint32_t	-	-	R
3	Alarm Data	58022	uint32_t	-	-	R
N	Alarm Number	58000+((N-1)*8)	uint32_t	-	-	R
N	Alarm Type	58002+((N-1)*8)	uint32_t	-	-	R
N	Alarm Time (UTC)	58004+((N-1)*8)	uint32_t	-	-	R
N	Alarm Data	58006+((N-1)*8)	uint32_t	-	-	R

EVENT NO	EVENT NAME
1	Modbus Address Changed
2	Modbus Speed Changed
3	Modbus Settings Changed
4	Device Switched on
5	Device Switched Off
6	Date/Time Current
7	Date/Time Changed
8	Date/Time Changed Remotely
9	Incorrect PIN
10	PIN Changed
11	Private PIN Entered
12	PIN Scam
13	Min-Max Values Deleted
14	Language Changed
15	Back to Default Settings
16	Network Frequency Changed
17	V1 Phase Break
18	V2 Phase Break
19	V3 Phase Break
20	Nominal Volt Changed
21	Measurement Connection Control Active
22	Measurement Connection Control Deactivated"
23	Neutral Control Active
24	Neutral Control Deactivated
25	Over Avr. Voltage (UM>) Control Active
26	Over Avr. Voltage (UM>) Control Deactivated
27	Over Avr. Voltage (UM>) Parameters Changed
28	Over Voltage (U>) Control Active
29	Over Voltage (U>) Control Deactivated
30	Over Voltage (U>) Parameters Changed
31	Over Voltage (U>>) Control Active
32	Over Voltage (U>>) Control Deactivated
33	Over Voltage (U>>) Parameters Changed
34	Low Voltage (U<) Control Active
35	Low Voltage (U<) Control Deactivated
36	Low Voltage (U<) Parameters Changed
37	Low Voltage (U<<) Control Activated
38	Low Voltage (U<<) Control Deactivated
39	Low Voltage (U<<) Parameters Changed
40	Over Frequency (F>) Control Active
41	Over Frequency (F>) Control Deactivated
42	Over Frequency (F>) Parameters Changed
43	Over Frequency (F>>) Control Active
44	Over Frequency (F>>) Control Deactivated
45	Over Frequency (F>>) Parameters Changed
46	Low Frequency (F<) Control Active
47	Low Frequency (F<) Control Deactivated
48	Low Frequency (F<) Parameters Changed
49	Low Frequency (F<<) Control Active
50	Low Frequency (F<<) Control Deactivated
51	Low Frequency (F<<) Parameters Changed
52	Rocof Control Active
53	Rocof Control Deactivated
54	Rocof Parameters Changed
55	Vector Shift Control Active
56	Vector Shift Control Deactivated
57	Vector Shift Parameters Changed
58	Voltage Range Control Active
59	Voltage Range Control Deactivated
60	Voltage Range Parameters Changed
61	Frequency Range Control Active
62	Frequency Range Control Deactivated
63	Frequency Range Parameters Changed
64	Feedback Control Active
65	Feedback Control Deactivated
66	Feedback Parameters Changed
67	Input (Y3) Control Active
68	Input (Y3) Control Deactivated
69	Input (Y4) Control Active
70	Input (Y4) Control Deactivated
71	Relay (K3) Control Active
72	Relay (K3) Control Deactivated

Instant Peak Values	Address	Type	Multiplier	Unit	W/R
1st Phase Min Voltage (LN)	11010	int32	0.1	V(Volt)	R
2nd Phase Min Voltage (LN)	11012	int32	0.1	V(Volt)	R
3rd Phase Min Voltage (LN)	11014	int32	0.1	V(Volt)	R
1st Phase Max Voltage (LN)	11020	int32	0.1	V(Volt)	R
2nd Phase Max Voltage (LN)	11022	int32	0.1	V(Volt)	R
3rd Phase Max Voltage (LN)	11024	int32	0.1	V(Volt)	R
Min Frequency	11050	int32	0.01	V(Volt)	R
Max Frequency	11052	int32	0.01	V(Volt)	R

Address	Command		W/R
9002	Delete My Peak Values	0xAA55	43605
9022	System Password Reset	0xAA55	43605
9024	Back to Default Settings	0xAA55	43605
9025	Device Reset	0xAA55	43605
9043	Delete Alarm List	0xAA55	43605
9050	Activate the System	0xAA55	43605
9051	Deactivate the System	0xAA55	43605
9052	Delete Breaker Counter Values	0xAA55	43605